



## Fastener Properties

Physical, mechanical and performance characteristics are material related properties which collectively give the fastener its service capability.

### Physical Properties

Inherent in the raw material and remain unchanged or only slightly altered in the fastener after its manufacture.

### Mechanical Properties

Identify the reaction of a fastener to applied loads. Properties such as hardness, ductility and tensile and yield strengths are all subject to significant change as the raw material is processed into a finished fastener.

### Performance Properties

Functional design features manufactured into the fastener to assist it to satisfy various service requirements. Properties of this type include prevailing torque, driving torque, locking ability and sealing. Choice of material and its metallurgical treatment influence magnitude rather than the presence of a particular performance property.

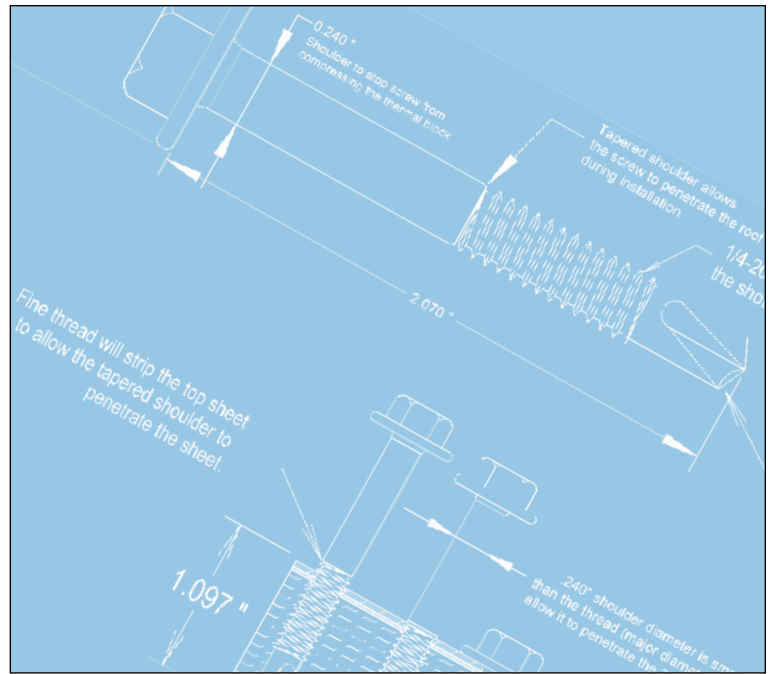

## Mechanical Properties

**Tensile Strength** - The maximum tension applied load a fastener can support prior to fracture.

**Yield Strength** - A tension applied load at which a fastener experiences a specified amount of permanent deformation: i.e., the material has been stressed beyond its elastic limit and has entered its plastic zone.

**Proof Load** - The tension applied load supported by the fastener without evidence of permanent deformation (about 90-93% of expected material yield).

**Hardness** - A measure of ability to resist abrasion and indentation. For carbon steel fasteners there is a close correlation between hardness and tensile strength. A similar pattern exists for stainless and non-ferrous materials, but it is not as precise as for carbon steels.

**Ductility** - Ability of a material to deform before it fractures. Elongation and reduction of area are common criteria to evaluate ductility.

**Toughness** - A material's ability to resist damage when stressed by impact or shock loading. Impact strength testing is rarely a testing requirement outside of aerospace applications.

**Shear Strength** - The maximum load applied normal to a fastener's axis that can be supported prior to fracture. Single shear is load occurring in one transverse plane, thus cutting the fastener into two pieces. Double shear is load applied in two planes, so that the fastener would be cut into three pieces.

**Torsional Strength** - Load usually expressed in terms of applied torque at which fastener fails by being twisted off about its axis. The torsional strength of the driving recess or wrenching surface is the torque which can be sustained without damage to the tool/fastener interface resulting in an undriveable condition.

**Fatigue Strength** - The maximum load a fastener can withstand for a specified number of repeated applications prior to failure. For a single load application to failure, the fatigue strength equals the static tensile strength. As the load is reduced, the fastener endures an increasing number of loading cycles until it reaches its other extreme of fatigue strength known as its endurance limit, which is the cyclic load the fastener can accept and survive indefinitely. Rarely used outside of aerospace applications, but helps compare relative performance to resist dynamic loadings.



## Drives



Slotted



One-Way  
Slot



Phillips  
(Type 1)



Phillips /Slot  
Combination



Phillips  
(Type 1A)



1A/Slot  
Combination



Phillips/  
Hex



Frearson  
(Type 2)



Quadrex®  
(Square/Phillips)



Square



6 Lobe  
(torx)



Hex  
Socket



Hex  
Washer

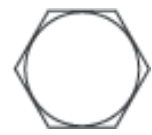

Hex

## Head Styles



Binder  
Head



Button  
Head



Bugle  
Head

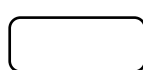

Cheese  
Head

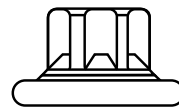

Ext 6 Lobe  
Washer Head



Fillister  
Head

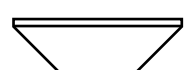

82° Flat  
Countersunk



82° U/C  
Countersunk

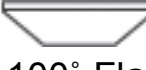

100° Flat  
Countersunk



90° Flat  
Countersunk

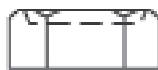

Ind Hex  
Head



Trimmed  
Hex Head



Trimmed  
Acorn



Hex Cap  
Screw



Hex  
Washer



Ind Hex  
Flange Head



82° Oval  
Head



90° Oval  
Head

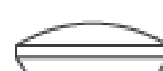

82° Oval  
U/C Head



90° Oval  
U/C Head



Pan Head  
(for slotted  
pan heads)

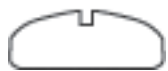

Pan Head  
(for recessed  
pan heads)

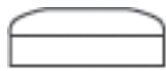

Pan Head  
(for socket product)



Round  
Head

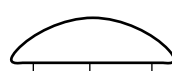

Round Head  
Square Neck



Full Crown  
Round  
Washer Head



Flat Top  
Round  
Washer Head



Socket  
Head

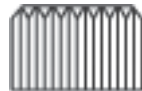

Knurled  
Head



Full Crown  
Truss Head



Flat Top  
Truss Head



Type UR



Pancake Head

## Under Head Configurations

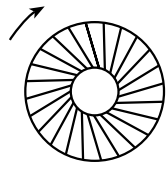

Full Serrations

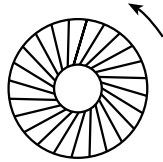

Full Reverse Serrations

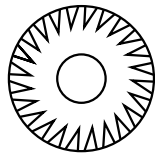

Spinlock Serrations

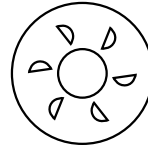

6 "Nibs" Serrations

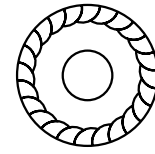

Partial Serrations



Chevron Serrations

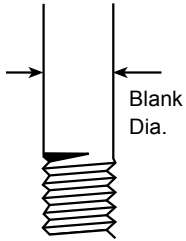

Reduced Body

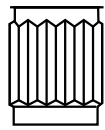

Knurled Shoulder

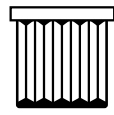

Ribbed Neck

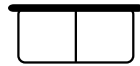

Square Shoulder

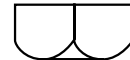

Square Neck

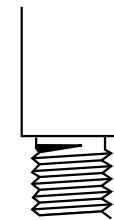

Shoulder

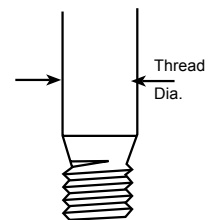

Full Body

## Washers

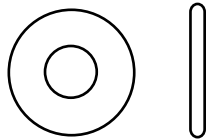

Beveled

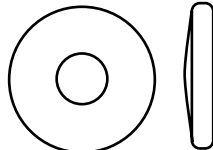

Conical

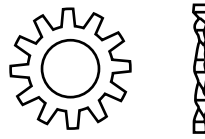

External

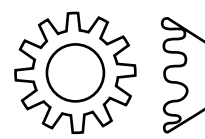

External Countersunk

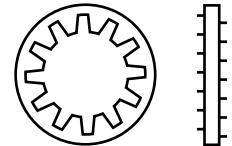

Internal

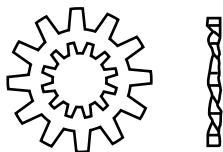

Internal / External

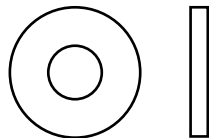

Flat

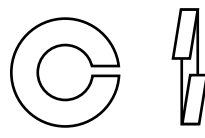

Slit Lock

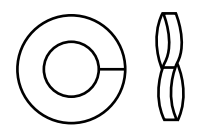

Split Wave

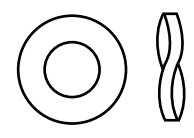

Wave Washer

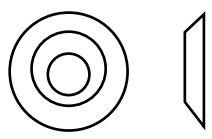

Ramp Conical

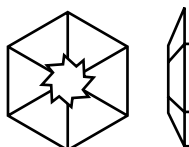

Pyramidal

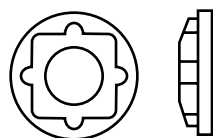

Square® Cone

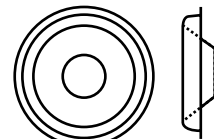

Finishing

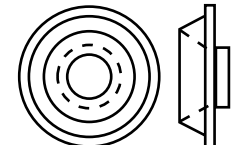

Flanged Finishing

# Point Styles

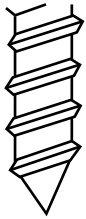

A



17



AB



22° Point

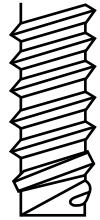

B



BP



T-Lobe B



25 (BT)



Pilot Point



Header Point

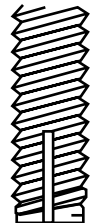

1 (D)



23 (T)



F



Type CA



T-Lobe CA

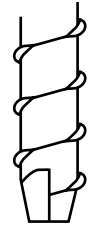

PF25



Fetter



Oval Point



Cup Point



Dog Point



Pilot Point

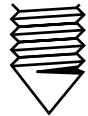

Cone Point



Type Designations for Tapping Screws and Metallic Drive Screws  
 Abstract of ANSI/ASME B18.6.4 1981

| Pictorial Representation        | ANSI/ASME Designation | Manufacturer's Designation |
|---------------------------------|-----------------------|----------------------------|
|                                 | AB                    | AB                         |
|                                 | B                     | B                          |
|                                 | BP                    | BP                         |
|                                 | BF                    | BF                         |
|                                 | BT                    | 25                         |
| Not recommended for new designs | C                     | C                          |
|                                 | D                     | 1                          |
|                                 | F                     | F                          |
|                                 | G                     | G                          |
|                                 | T                     | 23                         |
|                                 | U                     | U                          |

## Suggested hole sizes for tapping screws

Table 1 Suggested Hole Sizes for Thread Rolling Tapping Screws and Types D, F, G and T Thread Cutting Tapping Screws

| Nominal Screw Size | Hole Diameter |       |       | Closest Drill Size to Mean Hole Diameter |            |
|--------------------|---------------|-------|-------|--|------------|
|                    | Max           | Mean  | Min   | Drill Size                               | Drill Dia. |
| 2 - 56             | 0.078         | 0.076 | 0.074 | 48                                       | 0.076      |
| 2-64               |               | 0.077 |       |  |            |
| 3 - 48             | 0.090         | 0.087 | 0.084 | 44                                       | 0.086      |
| 3-56               |               | 0.089 |       |  |            |
| 4 - 40             | 0.100         | 0.097 | 0.094 | 41                                       | 0.096      |
| 4-48               |               | 0.100 |       |  |            |
| 5-40               | 0.113         | 0.110 | 0.107 | 35                                       | 0.110      |
| 5-44               |               | 0.112 |       |  |            |
| 6-32               | 0.123         | 0.119 | 0.115 | 31                                       | 0.120      |
| 6-40               |               | 0.124 |       |  |            |
| 8-32               | 0.150         | 0.146 | 0.141 | 20                                       | 0.147      |
| 8-36               |               | 0.148 |       |  |            |
| 10 - 24            | 0.170         | 0.165 | 0.160 | 19                                       | 0.166      |
| 10-32              |               | 0.172 | 0.167 |  |            |
| 12-24              | 0.198         | 0.192 | 0.186 | 11                                       | 0.191      |
| 12-28              |               | 0.196 |       |  |            |
| 1/4 - 20           | 0.228         | 0.221 | 0.214 | 2  | 0.221      |
| 1/4-28             |               | 0.230 |       |  |            |
| 5/16 - 18          | 0.289         | 0.281 | 0.273 | K  | 0.281      |
| 5/16-24            |               | 0.290 |       |  |            |
| 3/8 - 16           | 0.349         | 0.339 | 0.329 | R  | 0.339      |
| 3/8 - 24           |               | 0.353 |       |  |            |
| 7/16 - 14          | 0.409         | 0.397 | 0.385 | X  | 0.397      |
| 7/16-20            |               | 0.411 |       |  |            |
| 1/2 - 13           | 0.471         | 0.457 | 0.443 | 29/64                                    | 0.4531     |
| 1/2 - 20           |               | 0.475 |       |  |            |

Table 2 Suggested Hole Sizes for Types AB, B, and BP Thread Forming Tapping Screws and Types BF and BT Thread Cutting Tapping Screws

| Nominal Screw Size | Hole Diameter |       |       | Closest Drill Size to Mean Hole Diameter |            |
|--------------------|---------------|-------|-------|--|------------|
|                    | Max           | Mean  | Min   | Drill Size                               | Drill Dia. |
| 0-48               | 0.049         | 0.046 | 0.043 | 56                                       | 0.0465     |
| 1-42               | .063          | .059  | .055  | 53                                       | .0595      |
| 2 - 32             | .077          | .072  | .067  | 49                                       | .073       |
| 3-28               | .090          | .084  | .078  | 45                                       | .082       |
| 4-24               | .103          | .096  | .089  | 41                                       | .096       |
| 5-20               | .114          | .107  | .100  | 36                                       | .1065      |
| 6-20               | .124          | .116  | .108  | 32                                       | .116       |
| 7-19               | .138          | .129  | .120  | 30                                       | .1285      |
| 8 - 18             | .148          | .138  | .128  | 29                                       | .136       |
| 10-16              | .170          | .159  | .148  | 21                                       | .159       |
| 12-14              | .194          | .182  | .169  | 14                                       | .182       |
| 1/4-14             | .226          | .211  | .196  | 4  | .209       |
| 5/16-12            | .289          | .270  | .251  | 1  | .272       |
| 3/8-12             | .356          | .333  | .310  | 0  | .332       |
| 7/16-10            | .413          | .386  | .359  | w  | .386       |
| 1/2 - 10           | .480          | .449  | A18   | 29/64                                    | A531       |

### Formula

Mean Hole Dia = 0.98 x mean of thread major and minor diameters. Tolerance is plus and minus 7 percent of mean hole dia.

### Note

As a general practice, tapping torque should equal approximately 70% of the fasteners torsional strength.

### Formula

Mean Hole Dia = 1.015 x basic thread pitch diameter. Tolerance is plus and minus 3 percent of mean hole dia. No tolerances or drill sizes are given for tapping screws with fine threads except for the No. 10 size. Use of fine thread tapping screws is not encouraged.

### Torsional Strength Requirements For Tapping Screws

| Nominal Screw Size | Minimum Torsional Strength, lb-in. |                        |             |  |
|--------------------|------------------------------------|------------------------|-------------|--|
|                    | Types AB, B, BF, HP and BT         | Types C, D, F, G and T |             |  |
|                    |                                    | Coarse Thread          | Fine Thread |  |
| 2                  | 4                                  | 5                      | 6           |  |
| 3                  | 9                                  | 9                      | 10          |  |
| 4                  | 13                                 | 13                     | 15          |  |
| 5                  | 18                                 | 18                     | 20          |  |
| 6                  | 24                                 | 23                     | 27          |  |
| 7                  | 30                                 | -                      | -           |  |
| 8                  | 39                                 | 42                     | 47          |  |
| 10                 | 56                                 | 56                     | 74          |  |
| 12                 | 88                                 | 93                     | 108         |  |
| 1/4                | 142                                | 140                    | 179         |  |
| 5/16               | 290                                | 306                    | 370         |  |
| 3/8                | 590                                | 580                    | 710         |  |
| 7/16               | 620                                | 700                    | 820         |  |
| 1/2                | 1020                               | 1075                   | 1285        |  |

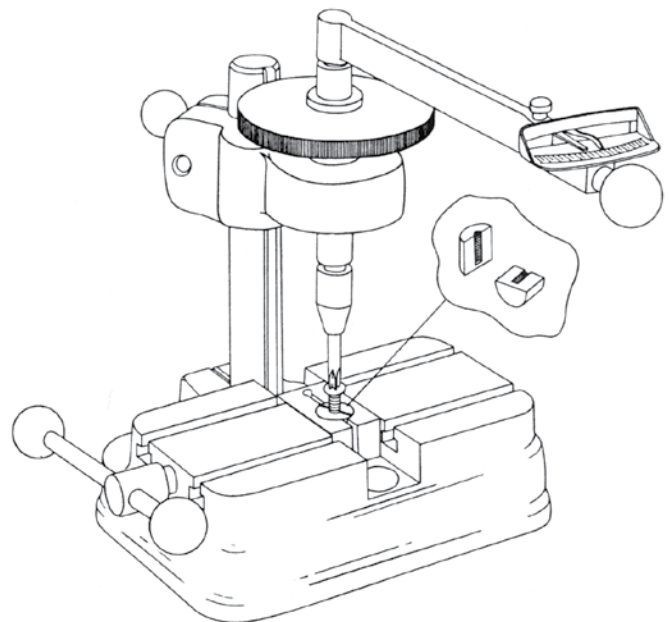

Typical Torsional Strength Test Fixture



# SELF-DRILLING TAPPING SCREW INFORMATION

## Mechanical and Performance Requirements for Types BSD and CSD Self-Drilling Tapping Screws SAE J78 Specifications

| Nominal Screw Size | Minimum Torsional Strength, lb-in |          | Hydrogen Embrittlement Test Torque, lb-in  |   |
|--------------------|-----------------------------------|----------|--|---|
|                    | Type BSD                          | Type CSD | Cadmium Plated Screws<br>Types BSD and CSD | Zinc Plated Screws<br>Types BSD and CSD |
| 4                  | 14                                | 14       | 10.5                                       | 12                                      |
| 6                  | 24                                | 24       | 18   | 20                                      |
| 8                  | 42                                | 48       | 36   | 41                                      |
| 10                 | 61                                | 65       | 49   | 55                                      |
| 12                 | 92                                | 100      | 72   | 85                                      |
| 1/4                | 150                               | 156      | 114  | 132                                     |

**BSD = Coarse Thread (Type B Thread)    CSD = Fine Thread (Type C Thread)**

**Major Diameter**

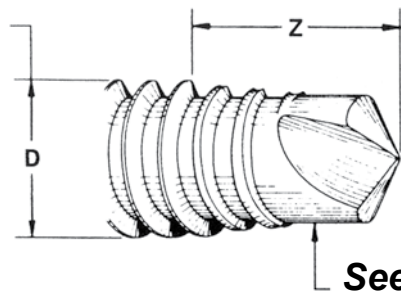

**Protrusion Allowance**

**See Note 1**

### Dimensions of Threads and Points for Types BSD and CSD Self-Drilling Tapping Screws

| Nominal Size<br>or Basic<br>Screw Diameter | Threads<br>Per inch | Type BSD               |       |                        |       | Type CSD                           |                  |                        |    | Types BSD and CSD                  |                  |  |                 |                |                 |              |                 |              |                 |              |       |
|--|---------------------|------------------------|-------|------------------------|-------|------------------------------------|------------------|------------------------|----|------------------------------------|------------------|--|-----------------|----------------|-----------------|--------------|-----------------|--------------|-----------------|--------------|-------|
|  |                     | D<br>Major<br>Diameter |       | d<br>Minor<br>Diameter |       | z<br>Protrusion<br>Allowance (Ref) |                  | D<br>Major<br>Diameter |    | z<br>Protrusion<br>Allowance (Ref) |                  | L<br>Minimum Practical Nominal Screw Lengths (Ref) |                 |                |                 |              |                 |              |                 |              |       |
|  |                     | Max                    | Mm    | Max                    | Mm    | Style 2<br>Point                   | Style 3<br>Point | Max                    | Mm | Style 2<br>Point                   | Style 3<br>Point | Style 2 Points                                     |                 | Style 3 Points |                 | Formed       |                 | Milled       |                 |              |       |
|  |                     |                        |       |                        |       |                                    |                  |                        |    |                                    |                  |  | 90 deg<br>Heads | Csk<br>Heads   | 90 deg<br>Heads | Csk<br>Heads | 90 deg<br>Heads | Csk<br>Heads | 90 deg<br>Heads | Csk<br>Heads |       |
| 4  | 0.1120              | 24                     | 0.114 | 0.110                  | 0.086 | 0.082                              | 0.163            | -                      | 40 | 0.1120                             | 0.1072           | 0.130  | -               | 5/16           | 3/8             | 3/8          | 7/16            | -            | -               | -            | -     |
| 6  | 0.1380              | 20                     | 0.139 | 0.135                  | 0.104 | 0.099                              | 0.190            | 0.220                  | 32 | 0.1380                             | 0.1326           | 0.152  | 0.172           | 5/16           | 3/8             | 3/8          | 7/16            | 3/8          | 7/16            | 7/16         | 1/2   |
| 8  | 0.1640              | 18                     | 0.166 | 0.161                  | 0.122 | 0.116                              | 0.211            | 0.251                  | 32 | 0.1640                             | 0.1586           | 0.162  | 0.202           | 3/8            | 7/16            | 7/16         | 1/2             | 7/16         | 1/2             | 1/2          | 9/16  |
| 10   | 0.1900              | 16                     | 0.189 | 0.183                  | 0.141 | 0.135                              | 0.235            | 0.300                  | 24 | 0.1900                             | 0.1834           | 0.193  | 0.258           | 7/16           | 1/2             | 15/32        | 19/32           | 1/2          | 9/16            | 9/16         | 21/32 |
| 12   | 0.2160              | 14                     | 0.215 | 0.209                  | 0.164 | 0.157                              | 0.283            | 0.353                  | 24 | 0.2160                             | 0.2094           | 0.223  | 0.293           | 1/2            | 5/8             | 17/32        | 21/32           | 1/2          | 5/8             | 21/32        | 25/32 |
| 1/4  | 0.2500              | 14                     | 0.246 | 0.240                  | 0.192 | 0.185                              | 0.318            | 0.393                  | 20 | 0.2500                             | 0.2428           | 0.275  | 0.350           | 1/2            | 5/8             | 17/32        | 11/16           | 1/2          | 5/8             | 11/16        | 27/32 |
| See Note2                                  |                     |                        |       |                        |       |                                    |                  | 3                      |    |                                    |                  |  |                 |                |                 |              |                 |              |                 |              |       |

**NOTES:**

1. Drill portion of points may be milled and/or cold formed and details of point taper and flute design shall be optional with the manufacturer, provided the screws meet the performance requirements specified in this standard and are capable of drilling the maximum panel thicknesses shown in Table 5 prior to thread pickup.
2. Where specifying nominal size in decimals, zeros preceding decimal and in fourth decimal place shall be omitted.
3. Protrusion allowance Z is the distance, measured parallel to the axis of screw, from the extreme end of the point to the first full form thread beyond the point and encompasses the length of drill point and the tapered incomplete threads. It is intended for use in calculating the maximum effective design grip length Y on the screw in accordance with the following:

$Y = L_{Min} - Z$

**For pullout data, refer to page 16-17 in TFC Fastening Systems Guide.**

**Grade Identification Markings for Carbon Steel Externally Threaded Fasteners**

| Grade Identification Marking | Specification                              | Material  | Nominal Size in.                         | Proof Load Stress ksi               | Tensile Strength Min ksi | Hardness Rockwell |              | See Note   |
|------------------------------|--|---|--|-------------------------------------|--------------------------|-------------------|--------------|------------|
|                              |  |   |  |                                     |                          | Min               | Max          |            |
| <br>No Mark                  | SAE J429 - Grade 1                         | Low or Medium Carbon Steel                                      | 1/4 thru 1 1/2                           | 33                                  | 60                       | B70               | B100         |            |
|                              | SAE J429 - Grade 2                         |   | 1/4 thru 3/4 over<br>over 3/4 thru 1 1/2 | 55<br>33                            | 74<br>60                 | B80<br>B70        | B100<br>B100 |            |
|                              | ASTM A307 - Grade A                        |   | 1/4 thru 4                               | -                                   | 60                       | B69               | B100         |            |
|                              | ASTM A307 - Grade B                        |   | 1/4 thru 4                               | -                                   | 60 Min<br>100 Max        | B69               | B95          |            |
|                              | SAE J429 - Grade 5<br>ASTM A449 - Type 1   | Medium Carbon Steel,<br>Quenched and Tempered                   | 1/4 thru 1 over<br>1 thru 1 1/2          | 85<br>74                            | 120<br>105               | C25<br>C19        | C34<br>C30   |            |
|                              | ASTM A449 - Type 1                         |   | over 1 1/2 thru 3                        | 55                                  | 90                       | 183               | 235          | 3          |
|                              | SAE J429 - Grade 5.1                       | Low or Medium Carbon Steel,<br>Quenched and Tempered            | N0.6 Thru 1/2                            | 85                                  | 120                      | C25               | C40          | 4          |
|                              | SAE J429 - Grade 5.2<br>ASTM A449 - Type2  | Low Carbon Martensite Steel,<br>Quenched and Tempered           | 1/4 thru 1                               | 85                                  | 120                      | C26               | C36          |            |
|                              |  |   |  |                                     |                          | C25               | C34          |            |
|                              | ASTM A325 - Type 1                         | Medium Carbon Steel<br>Quenched and Tempered                    |  |                                     |                          |                   |              | 5          |
|                              | ASTM A325 - Type 2                         | Low Carbon Martensite<br>Steel, Quenched and Tempered           | 1/2 Thru 1<br>over 1 to 1 1/2            | 85<br>74                            | 120<br>105               | C24<br>C19        | C35<br>C31   |            |
|                              | ASTM A325 - Type 3                         | Atmospheric Corrosion Resistant<br>Steel, Quenched and Tempered |  |                                     |                          |                   |              | 6          |
|                              | ASTM A354 - Grade BC                       | Medium Carbon Alloy Steel,<br>Quenched and Tempered             |  | 1/4 thru 2 1/2<br>over 2 1/2 thru 4 | 105<br>95                | 125<br>115        | C26<br>C22   | C36<br>C33 |
|                              | SAE J429 - Grade 8<br>ASTM A354 - Grade BD | Medium Carbon Alloy Steel,<br>Quenched and Tempered             | 1/4 thru 1 1/2                           | 120                                 | 150                      | C33               | C39          |            |
|                              |  |   | 1/4 thru 2 1/2 over<br>2 1/2 thru 4      | 120<br>105                          | 150<br>140               | C33<br>C31        | C39<br>C39   | 7          |
|                              |  |   |  |                                     |                          |                   |              |            |
|                              | SAE J429 - Grade 8.2                       | Low Carbon Martensite Alloy<br>Steel, Quenched and Tempered     | 1/4 thru 1                               | 120                                 | 150                      | C33               | C39          |            |
|                              | ASTM A490 - Type 1                         | Medium Carbon Alloy Steel,<br>Quenched and Tempered             | 1/2 Thru 1 1/2                           | 120                                 | 150 Min<br>170 Max       | C33               | C38          |            |
|                              | ASTM A490 - Type 2                         | Low Carbon Martensite Steel,<br>Quenched and Tempered           | 1/2 Thru 1                               | 120                                 | 150 Min<br>170 Max       | C33               | C38          |            |
|                              | ASTM A490 - Type 3                         | Atmospheric Corrosion Resistant<br>Steel, Quenched and Tempered | 1/2 Thru 1                               | 120                                 | 150 Min<br>170 Max       | C33               | C38          | 6          |

- NOTES:**
- In addition to the indicated grade marking, all grades included in this Table must be marked for manufacturer identification.
  - While hex heads are shown, grade markings apply equally to products with other head configurations.
  - Hardnesses are Brinell Hardness Numbers.
  - Grade 5.1 is a popular grade for sems
  - A325 Type 1 bolts may also be marked with 3 radial lines 1200 apart in addition to the A325 marking.
  - The bolt manufacturer, at his option, may add other markings to indicate the use of atmospheric corrosion resistant steel.
  - A354 Grade BD products, in sizes 1 1/2 in. and smaller, are identified as shown and, at the manufacturers option, may have the letters BD added. Larger sizes are marked only BD.



# CARBON STEEL BOLTS PROOF AND TENSILE STRENGTHS



## PROOF LOAD AND TENSILE STRENGTH REQUIREMENTS (a)

| Nominal Dia of Product and Threads per in. | Stress Area, in. <sup>2</sup> | Grade 1        |                         | Grade 2        |                         | Grade 4        |                         | Grades 5 and 5.2 <sup>B</sup> |                         | Grade 5.1      |                         | Grade 7        |                         | Grades 8, 8.1, 8.2 <sup>B</sup> |                         |
|--|-------------------------------|----------------|-------------------------|----------------|-------------------------|----------------|-------------------------|-------------------------------|-------------------------|----------------|-------------------------|----------------|-------------------------|---------------------------------|-------------------------|
|  |                               | Proof Load, lb | Tensile Strength Mm, lb | Proof Load, lb | Tensile Strength Mm, lb | Proof Load, lb | Tensile Strength Mm, lb | Proof Load, lb                | Tensile Strength Mm, lb | Proof Load, lb | Tensile Strength Mm, lb | Proof Load, lb | Tensile Strength Mm, lb | Proof Load, lb                  | Tensile Strength Mm, lb |
| <b>Coarse Thread Series - UNC</b>          |                               |                |                         |                |                         |                |                         |                               |                         |                |                         |                |                         |                                 |                         |
| No.6-32                                    | 0.00909                       | -              | -                       | -              | -                       | -              | -                       | -                             | -                       | 750            | 1,100                   | -              | -                       | -                               | -                       |
| 8-32                                       | 0.0140                        | -              | -                       | -              | -                       | -              | -                       | -                             | -                       | 1,200          | 1,700                   | -              | -                       | -                               | -                       |
| 10-24                                      | 0.0175                        | -              | -                       | -              | -                       | -              | -                       | -                             | -                       | 1,500          | 2,100                   | -              | -                       | -                               | -                       |
| 12-24                                      | 0.0242                        | -              | -                       | -              | -                       | -              | -                       | -                             | -                       | 2,050          | 2,900                   | -              | -                       | -                               | -                       |
| 1/4-20                                     | 0.0318                        | 1,050          | 1,900                   | 1,750          | 2,350                   | 2,050          | 3,650                   | 2,700                         | 3,800                   | 2,700          | 3,800                   | 3,350          | 4,250                   | 3,800                           | 4,750                   |
| 5/16-18                                    | 0.0524                        | 1,750          | 3,150                   | 2,900          | 3,900                   | 3,400          | 6,000                   | 4,450                         | 6,300                   | 4,450          | 6,300                   | 5,500          | 6,950                   | 6,300                           | 7,850                   |
| 3/8-16                                     | 0.0775                        | 2,550          | 4,650                   | 4,250          | 5,750                   | 5,050          | 8,400                   | 6,600                         | 9,300                   | 6,600          | 9,300                   | 8,150          | 10,300                  | 9,300                           | 11,600                  |
| 7/16-14                                    | 0.1063                        | 3,500          | 6,400                   | 5,850          | 7,850                   | 6,900          | 12,200                  | 9,050                         | 12,800                  | 9,050          | 12,800                  | 11,200         | 14,100                  | 12,800                          | 15,900                  |
| 1/2-13                                     | 0.1419                        | 4,700          | 8,500                   | 7,800          | 10,500                  | 9,200          | 16,300                  | 12,100                        | 17,000                  | 12,100         | 17,000                  | 14,900         | 18,900                  | 17,000                          | 21,300                  |
| 9/16-12                                    | 0.182                         | 6,000          | 10,900                  | 10,000         | 13,500                  | 11,800         | 20,900                  | 15,500                        | 21,800                  | 15,500         | 21,800                  | 19,100         | 24,200                  | 21,800                          | 27,300                  |
| 5/8-11                                     | 0.226                         | 7,450          | 13,600                  | 12,400         | 16,700                  | 14,700         | 25,400                  | 19,200                        | 27,100                  | 19,200         | 27,100                  | 23,700         | 30,100                  | 27,100                          | 33,900                  |
| 3/4-10                                     | 0.334                         | 11,000         | 20,000                  | 18,400         | 24,700                  | 21,700         | 38,400                  | 28,400                        | 40,100                  | -              | -                       | 35,100         | 44,400                  | 40,100                          | 50,100                  |
| 7/8-9                                      | 0.462                         | 15,200         | 27,700                  | 15,200         | 27,700                  | 30,000         | 53,100                  | 39,300                        | 55,400                  | -              | -                       | 48,500         | 61,400                  | 55,400                          | 69,300                  |
| 1-8  | 0.606                         | 20,000         | 36,400                  | 20,000         | 36,400                  | 39,400         | 69,700                  | 51,500                        | 72,700                  | -              | -                       | 63,800         | 80,600                  | 72,700                          | 90,900                  |
| 1-1/8-7                                    | 0.763                         | 25,200         | 45,800                  | 25,200         | 45,800                  | 49,600         | 87,700                  | 56,500                        | 80,100                  | -              | -                       | 80,100         | 101,500                 | 91,600                          | 114,400                 |
| 1-1/4-7                                    | 0.969                         | 32,000         | 58,100                  | 32,000         | 58,100                  | 63,000         | 111,400                 | 71,700                        | 101,700                 | -              | -                       | 101,700        | 127,700                 | 116,300                         | 145,400                 |
| 1-3/8-6                                    | 1.155                         | 38,100         | 69,300                  | 38,100         | 69,300                  | 75,100         | 132,800                 | 85,500                        | 121,300                 | -              | -                       | 121,300        | 153,600                 | 138,600                         | 173,200                 |
| 1-1/2-6                                    | 1.405                         | 46,400         | 84,300                  | 46,400         | 84,300                  | 91,300         | 161,600                 | 104,000                       | 147,500                 | -              | -                       | 147,500        | 186,900                 | 168,600                         | 210,800                 |
| <b>Fine Thread Series - UNF</b>            |                               |                |                         |                |                         |                |                         |                               |                         |                |                         |                |                         |                                 |                         |
| No.6-40                                    | 0.01015                       | -              | -                       | -              | -                       | -              | -                       | -                             | -                       | 850            | 1,200                   | -              | -                       | -                               | -                       |
| 8-38                                       | 0.01474                       | -              | -                       | -              | -                       | -              | -                       | -                             | -                       | 1,250          | 1,750                   | -              | -                       | -                               | -                       |
| 10-32                                      | 0.0200                        | -              | -                       | -              | -                       | -              | -                       | -                             | -                       | 1,700          | 2,400                   | -              | -                       | -                               | -                       |
| 12-28                                      | 0.0258                        | -              | -                       | -              | -                       | -              | -                       | -                             | -                       | 2,200          | 3,100                   | -              | -                       | -                               | -                       |
| 1/4-28                                     | 0.0364                        | 1,200          | 2,200                   | 2,000          | 2,700                   | 2,350          | 4,200                   | 3,100                         | 4,350                   | 3,100          | 4,350                   | 3,800          | 4,850                   | 4,350                           | 5,450                   |
| 5/16-24                                    | 0.0580                        | 1,900          | 3,500                   | 3,200          | 4,300                   | 3,750          | 6,700                   | 4,900                         | 6,950                   | 4,900          | 6,950                   | 6,100          | 7,700                   | 6,950                           | 8,700                   |
| 3/8-24                                     | 0.0878                        | 2,900          | 5,250                   | 4,800          | 6,500                   | 5,700          | 10,100                  | 7,450                         | 10,500                  | 7,450          | 10,500                  | 9,200          | 11,700                  | 10,500                          | 13,200                  |
| 7/16-20                                    | 0.1187                        | 3,900          | 7,100                   | 6,550          | 8,800                   | 7,700          | 13,650                  | 10,100                        | 14,200                  | 10,100         | 14,200                  | 12,500         | 15,800                  | 14,200                          | 17,800                  |
| 1/2-20                                     | 0.1599                        | 5,300          | 9,600                   | 8,800          | 11,800                  | 10,400         | 18,400                  | 13,600                        | 19,200                  | 13,600         | 19,200                  | 16,800         | 21,300                  | 19,200                          | 24,000                  |
| 9/16-18                                    | 0.203                         | 6,700          | 12,200                  | 11,200         | 15,000                  | 13,200         | 23,300                  | 17,300                        | 24,400                  | 17,300         | 24,400                  | 21,300         | 27,000                  | 24,400                          | 30,400                  |
| 5/8-18                                     | 0.256                         | 8,450          | 15,400                  | 14,100         | 18,900                  | 16,600         | 29,400                  | 21,800                        | 30,700                  | 21,800         | 30,700                  | 26,900         | 34,000                  | 30,700                          | 38,400                  |
| 3/4-16                                     | 0.373                         | 12,300         | 22,400                  | 20,500         | 27,600                  | 24,200         | 42,900                  | 31,700                        | 44,800                  | -              | -                       | 39,200         | 49,600                  | 44,800                          | 56,000                  |
| 7/8-14                                     | 0.509                         | 16,800         | 30,500                  | 16,800         | 30,500                  | 33,100         | 58,500                  | 43,300                        | 61,100                  | -              | -                       | 53,400         | 67,700                  | 61,100                          | 76,400                  |
| 1 -12                                      | 0.663                         | 21,900         | 39,800                  | 21,900         | 39,800                  | 43,100         | 76,200                  | 56,400                        | 79,600                  | -              | -                       | 69,600         | 88,200                  | 79,600                          | 99,400                  |
| 1-1/4 uns                                  | 0.679                         | 22,400         | 40,700                  | 22,400         | 40,700                  | 44,100         | 78,100                  | 57,700                        | 81,500                  | -              | -                       | 71,300         | 90,300                  | 81,500                          | 101,900                 |
| 1-1/8-12                                   | 0.856                         | 28,200         | 51,400                  | 28,200         | 51,400                  | 55,600         | 98,400                  | 83,300                        | 89,900                  | -              | -                       | 89,900         | 113,800                 | 102,700                         | 128,400                 |
| 1-1/4-12                                   | 1.073                         | 35,400         | 64,400                  | 35,400         | 64,400                  | 69,700         | 123,400                 | 79,400                        | 112,700                 | -              | -                       | 112,700        | 142,700                 | 128,800                         | 161,000                 |
| 1-3/8-12                                   | 1.315                         | 43,400         | 78,900                  | 43,400         | 78,900                  | 85,500         | 151,200                 | 97,300                        | 138,100                 | -              | -                       | 138,100        | 174,900                 | 157,800                         | 197,200                 |
| 1-1/2-12                                   | 1.581                         | 52,200         | 94,900                  | 52,200         | 94,900                  | 102,800        | 181,800                 | 117,000                       | 116,000                 | -              | -                       | 166,000        | 210,300                 | 189,700                         | 237,200                 |

A) Proof loads and tensile strengths are computed by multiplying the proof load stresses and tensile strength stresses given in Table 1 by the stress area of the thread.

The stress area of sizes and thread series not included in this table may be computed from the formula:  $A_s = 0.7854 [D - \frac{0.9743}{n}]^2$  where D equals nominal diameter in inch, and n equals threads per inch.

B) Grades 5.2 and 8.2 applicable to sizes 1/4 through 1 in.

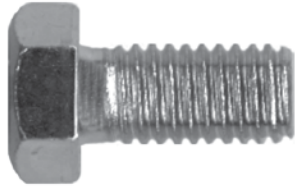

**MECHANICAL REQUIREMENTS FOR STAINLESS  
STEEL BOLTS, SCREWS, STUDS AND NUTS**

| Grade <sup>1</sup> | General Description                               | Mechanical Requirements             |                          |   |                          |                               |                       |                       |                       |
|--------------------|---|-------------------------------------|--------------------------|---|--------------------------|-------------------------------|-----------------------|-----------------------|-----------------------|
|                    |   | Bolts <sup>1</sup> Screws And Studs |                          |   |                          |                               | Nuts                  |                       |                       |
|                    |   | Full Size Bolts, Screws, Studs      |                          | Machined Test Specimens Of Bolts, Screws, Studs |                          |                               |                       |                       |                       |
|                    |   | Yield <sup>2</sup> Strength min ksi | Tensile Strength min ksi | Yield <sup>2</sup> Strength min ksi             | Tensile Strength min ksi | Elongation <sup>3</sup> % Min | Hardness Rockwell Min | Proof Load Stress ksi | Hardness Rockwell Min |
| 303-A              | Austenitic Stainless Steel Sol. Annealed          | 30                                  | 75                       | 30  | 75                       | 20                            | B75                   | 75                    | B75                   |
| 304-A              | Austenitic Stainless Steel Sol. Annealed          | 30                                  | 75                       | 30  | 75                       | 20                            | B75                   | 75                    | B75                   |
| 304                | Austenitic Stainless Steel Cold Worked            | 50                                  | 90                       | 45  | 85                       | 20                            | B85                   | 90                    | B85                   |
| 305-A              | Austenitic Stainless Steel Sol. Annealed          | 30                                  | 75                       | 20  | 75                       | 20                            | B70                   | 75                    | B70                   |
| 305                | Austenitic Stainless Steel Cold Worked            | 50                                  | 90                       | 45  | 85                       | 20                            | B85                   | 90                    | B85                   |
| 316-A              | Austenitic Stainless Steel Sol. Annealed          | 30                                  | 75                       | 30  | 75                       | 20                            | B70                   | 75                    | B70                   |
| 316                | Austenitic Stainless steel Sol. Annealed          | 50                                  | 90                       | 45  | 85                       | 20                            | B85                   | 90                    | B85                   |
| 316-SH             | Austenitic Stainless Steel Strain Hardened        | See Note 6                          | See Note 6               | See Note 6                                      | See Note 6               | 15                            | C25                   | See Note 6            | C20                   |
| 410-H              | Stainless Steel Hardened and Tempered             | 95                                  | 125                      | 95  | 125                      | 20                            | C22                   | 125                   | C22                   |
| 410-HT             | Martensitic Stainless Steel Hardened and Tempered | 135                                 | 180                      | 135   | 180                      | 12                            | C36                   | 180                   | C36                   |
| 416-H              | Martensitic Stainless Steel Hardened and Tempered | 95                                  | 125                      | 95  | 125                      | 20                            | C22                   | 125                   | C22                   |
| 416-HT             | Martensitic Stainless Steel Hardened and Tempered | 135                                 | 180                      | 135   | 180                      | 12                            | C36                   | 150                   | C36                   |
| 430                | Ferritic Stainless Steel                          | 40                                  | 70                       | 40  | 70                       | 20                            | B75                   | 70                    | B75                   |



# CARBON STEEL NUTS PROOF LOADS AND HARDNESS

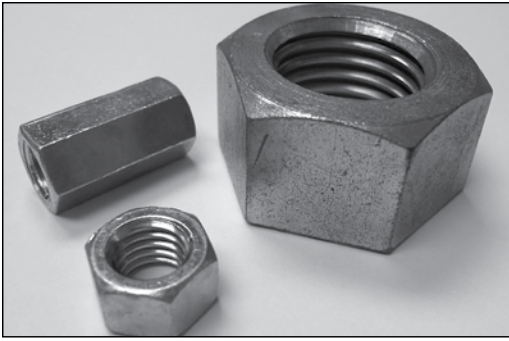

## GRADE IDENTIFICATION MARKINGS FOR POPULAR GRADES OF CARBON STEEL NUTS

| Grade Identification Marking | Specification         | Material  | Nominal Size in. | Proof Load Stress ksi | Hardness Rockwell |     | See Note |
|------------------------------|-----------------------|---|------------------|-----------------------|-------------------|-----|----------|
|                              |                       |   |                  |                       | Min               | Max |          |
|                              | ASTM A 563 - Grade 0  | Carbon Steel  | 1/4 thru 1 1/2   | 69                    | B55               | C32 | 3, 4     |
|                              | ASTM A 563 - Grade A  | Carbon Steel  | 1/4 thru 1 1/2   | 90                    | B68               | C32 | 3, 4     |
|                              | ASTM A 563 - Grade B  | Carbon Steel  | 1/4 thru 1       | 120                   | B55               | C32 | 3, 4     |
| over 1 thru 1 1/2            |                       |   | 105              |                       |                   |     |          |
|                              | ASTM A563 - Grade C   | Carbon Steel, May Be Quenched and Tempered                          | 1/4 thru 4       | 144                   | B78               | C38 | 5        |
|                              | ASTM A563 - Grade C3  | Atmospheric Corrosion Resistant Steel, May Be Quenched and Tempered | 1/4 thru 4       | 144                   | B78               | C38 | 5, 9     |
|                              | ASTM A563 - Grade D   | Carbon Steel, May Be Quenched and Tempered                          | 1/4 thru 4       | 150                   | B84               | C38 | 6        |
|                              | ASTM A563 - Grade DH  | Carbon Steel, Quenched and Tempered                                 | 1/4 thru 4       | 175                   | C24               | C38 | 6        |
|                              | ASTM A563 - Grade DH3 | Atmospheric Corrosion Resistant Steel, Quenched and Tempered        | 1/4 thru 4       | 175                   | C24               | C38 | 5, 9     |
|                              | ASTM A194 - Grade 1   | Carbon Steel  | 1/4 thru 4       | 130                   | B70               | -   | 7        |
|                              | ASTM A194 - Grade 2   | Medium Carbon Steel   | 1/4 thru 4       | 150                   | 159               | 352 | 7, 8     |
|                              | ASTM A194 - Grade 2H  | Medium Carbon Steel, Quenched and Tempered                          | 1/4 thru 4       | 175                   | C24               | C38 | 7        |
|                              | ASTM A194 - Grade 2HM | Medium Carbon Steel, Quenched and Tempered                          | 1/4 thru 4       | 150                   | 159               | 237 | 7, 8     |
|                              | ASTM A194 - Grade 4   | Medium Carbon Alloy Steel, Quenched and Tempered                    | 1/4 thru 4       | 175                   | C24               | C38 | 7        |
|                              | ASTM A194 - Grade 7   | Medium Carbon Alloy Steel, Quenched and Tempered                    | 1/4 thru 4       | 175                   | C24               | C38 | 7        |
|                              | ASTM A194 - Grade 4   | Medium Carbon Alloy Steel, Quenched and Tempered                    | 1/4 thru 4       | 150                   | 159               | 237 | 7        |
| See note 1,2,10              |                       |   |                  |                       |                   |     |          |

**NOTES:**

1. In addition to the indicated grade marking, all grades, except AS63 grades 0, A and B, must be marked for manufacturer identification.
2. The markings shown for all grades of A194 nuts are for cold formed and hot forged nuts. When nuts are machined from bar stock the nut must be additionally marked with the letter 'B'.
3. Nuts are not required to be marked unless specified by the purchaser. When marked, the identification marking shall be the grade letter 0, A or B.
4. Properties shown are those of non-plated or non-coated coarse thread hex nuts.
5. Properties shown are those of coarse thread heavy hex nuts.
6. Properties shown are those of coarse thread heavy hex nuts.
7. Properties shown are those of coarse and 8-pitch thread heavy hex nuts.
8. Hardnesses are Brinell Hardness Numbers.
9. The nut manufacturer; at his option, may add other markings to indicate the use of atmospheric corrosion resistant steel.
10. Specifications - ASTM A563 - Carbon and Alloy Steel Nuts / ASTM A194 - Carbon and Alloy Steel Nuts for Bolts for High Pressure and High Temperature Service