



Our Vibration Resistant Thread (VRT[®]) is designed to significantly increase back-out torque and reduce the potential for leaks.

VRT[®] keeps the fastener tighter in applications where expansion, contraction and vibration are a concern.









Independent tests verify that VRT[®] produces 3-1/2 times more back-out resistance than a standard thread.



Sizes and Technical Data Sheet

Light Gauge Applications

Maximum Drilling Thickness: .090"

Description	Part Number	Carton Quantity	WT Per M Pcs
 1/4" -14 X 7/8" DP1/LAP w/VRT [®] CONCEALOR [®] Pancake Head w/Bonded Sealing Washer TRI-SEAL [™] Coated 1,000Hrs Salt Spray	14087C1TSVBW	2,500 pcs 250/Bag	13.5#
 1/4" -14 X 7/8" DP1/LAP w/VRT [®] BLAZER [®] Flange Head w/Sealing Washer TRI-SEAL [™] Coated 1,000Hrs Salt Spray	14087HW1CSTS VW	2,500 pcs 250/Bag	13.5#
 1/4" -14 X 7/8" DP1/LAP w/VRT [®] BLAZER [®] TRI-SEAL [™] Coated 1,000Hrs Salt Spray	14087HW1CSTS V	2,500 pcs 250/Bag	10.2#
 1/4" -14 X 7/8" DP1/LAP w/VRT [®] BLAZER [®] w/Bonded Sealing Washer TRI-SEAL [™] Coated 1,000Hrs Salt Spray	14087HW1CSTS VBW	2,500 pcs 250/Bag	13.5#
 1/4" -14 X 7/8" DP1/LAP w/VRT [®] BLAZER [®] Stainless Cap Head w/Sealing Washer TRI-SEAL [™] Coated 1,000Hrs Salt Spray	14087HW1CSTS VWSC	2,500 pcs 250/Bag	13.5#
 1/4" -14 X 7/8" DP1/LAP w/VRT [®] BLAZER [®] Zinc Cap Head w/Sealing Washer TRI-SEAL [™] Coated 1,000Hrs Salt Spray	14087HW1CSTS VWZC	2,000 pcs 250/Bag	13.5#
 1/4" -14 X 1-1/8" DP1/LAP w/VRT [®] BLAZER [®] Stainless Cap Head w/Sealing Washer TRI-SEAL [™] Coated 1,000Hrs Salt Spray	14112HW1CSTS VWSC	2,000 pcs 250/Bag	19.3#
 #17-14 X 1" TYPE AB w/VRT [®] TAPPER w/Bonded Sealing Washer (3/4"OD) TRI-SEAL [™] Coated 1,000Hrs Salt Spray	17100HHACSTS VOW	2,000 pcs 250/Bag	20#

Technical Data

Specifications

BLAZER Drill Screws conforms to SAE J-78 for self-drilling tapping screws.

#17 TAPPER conforms to ANSI/ASME B18.6.4 for tapping screws.

Material

Carbon Steel: C1022
Stainless Cap: 304 SS
Zinc Cap: Zamac 5

Tensile Strength

1/4-14: 4,275 lbs.
#17-14: 5,200 lbs.

Torsional Strength

1/4-14: 150 lbs-inch
#17-14: 175 lbs-inch

*Pullout (Pounds)

	1/4-14	#17-14
26ga	173	201
24ga	240	280
22ga	337	342
20ga	387	395
18ga	657	725
16ga	1,250	1,345

Corrosion Resistance

TRI-SEAL
Salt Spray: 1,000 hrs minimum.
No Red Rust

Sealing Washers

Flange Head:
EPDM Cut Tubular

Bonded Washer:

EPDM Vulcanized to G-90 Galvanized Steel. (15MM O.D.).

* Pullout values are ultimate averages based on laboratory tests. Appropriate factors of safety should be used. TFC assumes no liability for the use if this information.

BLAZER® WITH BONDED SEALING WASHER

- ▶ **BOND-SEALER™** is a sealing washer that has EPDM vulcanized to a 20 Gauge galvanized backing that will withstand harsh weather conditions.
- ▶ **TRI-SEAL™** long life coated for superior corrosion protection.

SIZES AND PERFORMANCE SPECIFICATIONS

	Size	Point Type	Drilling Thickness	Attachment Thickness	Box Quantity
A	#10-16 x 1"	DP3	.036" - .175"	.575"	5M
	#10-16 x 1-1/2"	DP3	.036" - .175"	1.075"	3M
B	#12-14 x 3/4"	DP3	.036" - .210"	.290"	5M
	#12-14 x 1"	DP3	.036" - .210"	.525"	3.5M
	#12-14 x 1-1/4"	DP3 LP	.036" - .210"	.750"	3.5M
	#12-14 x 1-1/2"	DP3	.036" - .210"	1.000"	2.5M
	#12-14 x 2"	DP3	.036" - .210"	1.500"	2M
	#12-14 x 2-1/2"	DP3	.036" - .210"	2.000"	1M
C	#12-24 x 1-1/4"	DP5	.250" - .500"	.375"	3.5M
	#12-24 x 1-1/2"	DP5	.250" - .500"	.625"	2.5M
	#12-24 x 2"	DP5	.250" - .500"	1.125"	2M
D	1/4-14 x 7/8"	DP1 W/VRT*	.036" - .090"	.325"	2.5M
E	1/4-14 x 3/4"	DP3	.036" - .250"	.210"	2.5M
	1/4-14 x 1"	DP3	.036" - .250"	.460"	2.5M
	1/4-14 x 1-1/4"	DP3	.036" - .250"	.710"	2M
	1/4-14 x 1-1/2"	DP3	.036" - .250"	.960"	2M
	1/4-14 x 2"	DP3	.036" - .250"	1.460"	1.5M
	1/4-14 x 2-1/2"	DP3	.036" - .250"	2.460"	1M
	1/4-14 x 4"	DP3	.036" - .250"	3.460"	500
	1/4-14 x 5"	DP3	.036" - .250"	4.460"	500
F	1/4-14 x 6"	DP3	.036" - .250"	5.460"	250
	1/4-20 x 4"	DP5	.250" - .500"	3.000"	500
	1/4-20 x 5"	DP5	.250" - .500"	4.000"	500
	1/4-20 x 6"	DP5	.250" - .500"	5.000"	250
	1/4-20 x 7"	DP5	.250" - .500"	6.000"	150
	1/4-20 x 8"	DP5	.250" - .500"	7.000"	150

MATERIAL: C1018-1022 Carbon Steel
PLATING: .0003" Min. Zinc w/TRI-SEAL™ Coating (1,000hrs Salt Spray)

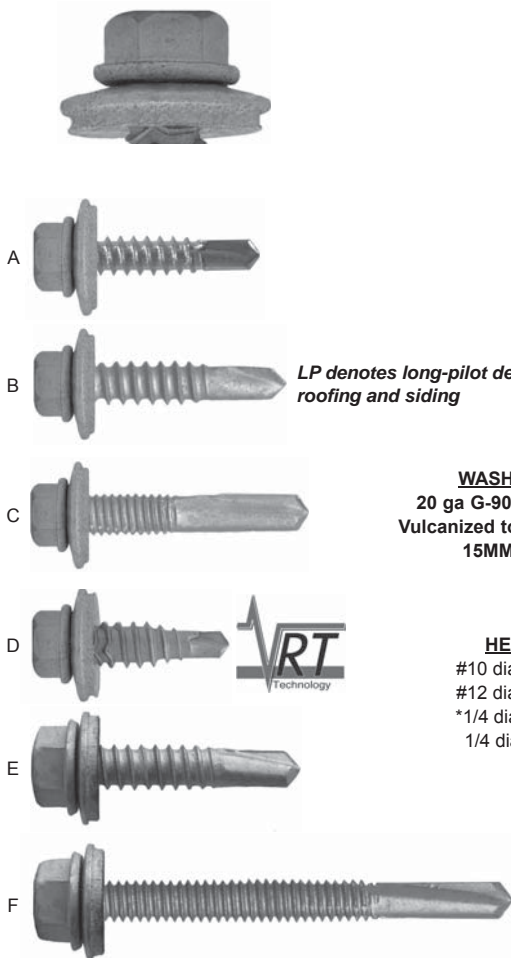

LP denotes long-pilot design for metal roofing and siding

WASHER DETAILS
20 ga G-90 Galvanized Steel
Vulcanized to .062" thick EPDM
15MM OD Washer

HEAD TYPE
#10 dia: 5/16" HWH
#12 dia: 5/16" HWH
*1/4 dia: 5/16" HWH
1/4 dia: 3/8" HWH

Proper Fastener Installation

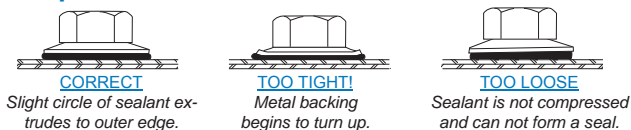

To assure a proper seal, torque the fastener until the EPDM sealant extrudes to the outer edge of the backing material.

BLAZER® FLANGE-SEAL HEAD WITH EPDM WASHER

- ▶ **FLANGE-SEAL™** self-sealing fastener has a deep undercut head that entraps the EPDM sealing washer to assure a leak free seal.
- ▶ **TRI-SEAL™** long-life coated for superior corrosion protection.

SIZES AND PERFORMANCE SPECIFICATIONS

	Size	Point Type	Drilling Thickness	Attachment Thickness	Box Quantity
G	#12-14 x 3/4"	DP2/DP3	.036" - .210"	.290"	5M
	#12-14 x 1"	DP2/DP3	.036" - .210"	.525"	3.5M
	#12-14 x 1-1/4"	DP2/DP3 LP	.036" - .210"	.750"	3.5M
	#12-14 x 1-1/2"	DP2/DP3	.036" - .210"	1.000"	2.5M
	#12-14 x 2"	DP2/ DP3	.036" - .210"	1.500"	2M
	#12-14 x 2-1/2"	DP2/DP3	.036" - .210"	2.000"	1M
H	1/4-14 x 7/8"	DP1 W/VRT*	.036" - .090"	.325"	2.5M
I	1/4-14 x 3/4"	DP3*	.036" - .250"	.210"	2.5M
	1/4-14 x 1"	DP3*	.036" - .250"	.460"	2.5M
	1/4-14 x 1-1/2"	DP3*	.036" - .250"	.960"	2M

MATERIAL: C1018-1022 Carbon Steel
PLATING: .0003" Min. Zinc w/TRI-SEAL™ Coating (1,000hrs Salt Spray)

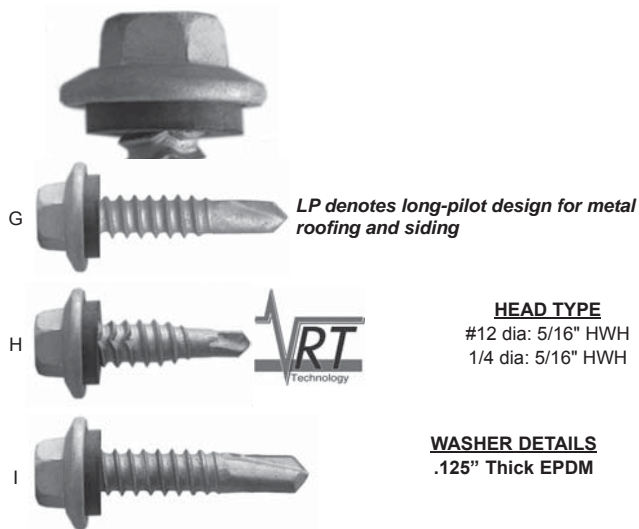

LP denotes long-pilot design for metal roofing and siding

HEAD TYPE
#12 dia: 5/16" HWH
1/4 dia: 5/16" HWH

WASHER DETAILS
.125" Thick EPDM