

TWIN LOC-NAIL SPECIFICATIONS

BASE SHEET, RECOVERY BOARD, AND INSULATION TO LIGHTWEIGHT INSULATING CONCRETE, STRUCTURAL WOOD FIBER, AND POURED GYPSUM

COMPOSITION

Factory pre-assembled components consisting of:

Tube: Precision formed from coated steel to prevent corrosion. The tube is shaped to easily penetrate decking and existing membranes.

Disk: Precision formed from coated steel to prevent corrosion, 2.7" diameter. Securely clamped to tube and rib reinforced to resist cupping.

Locking Staple: Precision formed from high tensile steel wire. Coated to prevent corrosion.

TECHNICAL DATA

Approvals: Twin Loc-Nails maintain Factory Mutual and Miami-Dade County Approvals.

Fastening Pattern: Consult Factory Mutual or Miami-Dade County requirements for recommended pattern in normal, exposed, and hurricane areas.

Field Testing: On-site withdrawal testing should always be performed to evaluate the ability of the roofing substrate to satisfactorily accept and retain fasteners. Such testing may alter fastener selection and modify applicable fastening patterns. The Twin Loc-Nail should always be embedded into the structural roof deck to a depth of at least 1"

INSTALLATION

Equipment: Always use an ES Twin Loc Driver. Consult ES Products for the specific driver for your application.

Method: Drive Twin Loc-Nail perpendicular to roof deck, seating cap flush with roofing surface. Once tube is set, drive the locking staple into the tube/disk unit until the top of the staple is flush with the cap (see illustration).

Operation: When locking staple is driven, its dual wire legs diverge, anchoring the fastener in place (see illustration). Uplift resistance may vary depending on the density and integrity of the substrate.

Availability: The Twin Loc-Nail is a patented product manufactured only by ES Products, Inc. and distributed by leading roofing material and equipment wholesalers throughout the United States.

Packaging: 1.4", 1.8", 2.8", and 3.8" Twin Loc-Nails packaged 500 per carton. Gross weight: 1.4"- 26 lbs; 1.8"- 28 lbs; 2.8"- 34 lbs; 3.8"- 42 lbs. 4.8" Twin Loc-Nails packaged 250 per carton. Gross weight: 27 lbs. Shrink wrapped and palletized.

PROUDLY MADE IN THE U.S.A.

Warranty: ES Products, LLC warrants its products for one year from date of sale against defective workmanship and material, and its liability therefore shall be limited to replacing defective products reported defective during the warranty period. ES Products is not responsible for any failure attributable to improper use or installation in any manner inconsistent with manufacturer's specifications. THIS WARRANTY IS IN LIEU OF ANY OTHER WARRANTY, EXPRESS OR IMPLIED, ALL OF WHICH ARE EXPRESSLY DISCLAIMED INCLUDING ANY WARRANTY OF MERCHANTABILITY AND ANY WARRANTY OF FITNESS FOR PARTICULAR USE. This warranty provides specific legal rights and remedies that may vary from state to state.

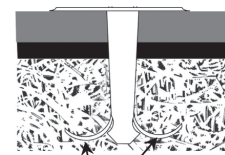
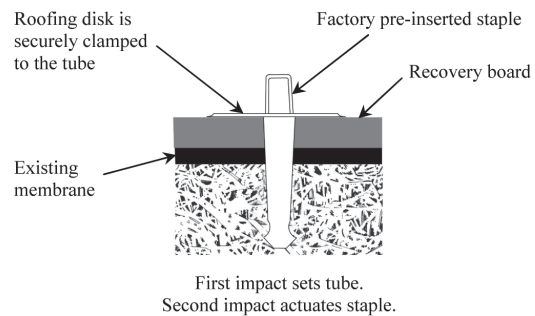
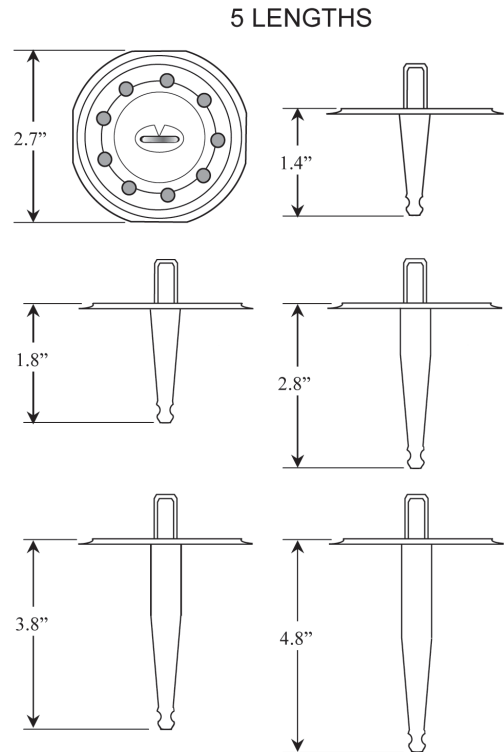

ESPRODUCTS

280 Franklin Street • Bristol, RI 02809
800-493-ROOF (7663) • esproducts.com